

DUPLEX WORLD *UPDATE*

A technical event update for the global duplex community

Inside:

- Duplex World Call for Papers
- Technical duplex articles
- Column: Achieving G48 corrosion tests

Serving the duplex community

Welcome to the first Duplex World Update!

This technical update is available as a service to our global corrosion resistant alloy community, built up over thirty years by the Stainless Steel World and Duplex World brands.

The Duplex World events have brought together material specialists, engineers, end-users, and manufacturers in that sector for decades. This publication aims to help that community stay up-to-date on developments. This year, as the world struggled with the Covid-19 pandemic, we held our conference online for the first time. The response from our community, who joined us from every corner of the globe, reinforced our belief that there is a real need for in-depth technical information on the manufacture, use of, and markets for duplex stainless steel.

Looking ahead to 2022, we are already planning the next Duplex World Seminar & Summit, which takes place 1 & 2 November 2022 in Rotterdam, the Netherlands.

We're running our event Heat Exchanger World right alongside so that visitors to both events can enjoy the synergies between these two sectors, at no extra cost.

The Call for Papers for Duplex World is now out, so make sure that you send in your abstract, or book your exhibition stand. If you'd like to have a chat about how you can join the conference for the first time, feel free to call or drop me an email so we can discuss the possibilities.



Best wishes,
Joanne McIntyre
Editor in Chief, Stainless Steel World
Organiser of the Duplex World Seminar
Tel: +31 575 585 298
Email: j.mcintyre@kci-world.com

Call for Papers Duplex World 2022

Don't miss the opportunity to present a paper or join a workshop discussion at Duplex World 2022, 1 & 2 November in Rotterdam, the Netherlands.

Send your abstract before 21 February to j.mcintyre@kci-world.com

More information on the following pages!



CONTENTS

Duplex World Call for Papers 4

The performance of duplex stainless steels in caustic soda 6

This paper shows that duplex stainless steels have good resistance to both general corrosion and stress corrosion cracking in caustic solutions over a wide range of concentrations and temperatures.

Lasers for production optimisation of rolling products 9

Production automation can address challenges regarding delivery times, production costs and product quality driven by high requirements from certain automotive industries.

Achieving ASTM G48 corrosion test at 40°C on super duplex 10

Peter Stones provides advice to a welding company having difficulty achieving the required ASTM G48 test when welding super duplex.

Experimenting with welding superduplex without filler metal 12

This study looks at the welding of small diameter and 'thin' wall thickness superduplex pipes with orbital GTAW, without filler metal, using an orbital closed head welding machine.

Continual improvement: duplex stainless steels prosper with better formability 16

Despite setbacks earlier this year, the oil & gas industry is recovering, and new forming techniques – and especially powder-based additive manufacturing methods – make duplex an increasingly attractive alternative to other grades.

Formula to convert Rockwell & Vickers hardness scales for duplex stainless steels 19

A recent study has successfully evaluated and documented the correlation between the two hardness scales.

Make sure you don't miss the second edition of Duplex World Update. Email j.mcintyre@kci-world.com to join our mailing list.

Duplex World Update 1, October 2021
Duplex World Update is published by KCI Publishing.
Mailing Address:
KCI Publishing B.V., PO Box 825,
7400 AV Deventer, The Netherlands
kci.deventer@kci-world.com
www.stainless-steel-world.net

The publishers and the authors state that this brochure has been compiled meticulously and to the best of their knowledge, however, the publisher and the authors can in no way guarantee the accuracy or completeness of the information. The publisher and authors therefore do not accept any liability for any damage resulting from actions or decision based on the information in question. Users of this magazine are strongly advised not to use this information solely, but to rely on their professional knowledge and experience, and to check the information to be used. KCI Publishing cannot guarantee the accuracy of information provided by participating companies and authorities.

The publisher reserves the right to combine, delete and change sections.
The publisher reserves the right to edit and re-use (parts of) the articles and to distribute the information by any means. All rights reserved. No part of this publication may be reproduced, stored in a retrieval system or transmitted, in any form or by any means, electronic or mechanical, photocopying recording or otherwise, without the written permission of the publisher.
© 2021 All rights reserved

Join the leading knowledge, networking and business event for the global duplex community!

Duplex World unites duplex researchers, manufacturers, end-users and suppliers in an open and focused forum.

Network with the leading minds driving ahead innovation and excellence in the field of materials science!



- ✓ Technical conference
- ✓ Interactive workshops
- ✓ End-user panel discussions
- ✓ Leading manufacturers & suppliers
- ✓ Networking & social program



Call for papers

Duplex World is the ideal platform to profile your expertise, network with industry peers, and share your knowledge with the international materials community.

1 Submit a paper

If you would like to give a technical presentation please submit a 300-500 word abstract outlining the topic and content of your material for consideration by the Steering Committee by **21 February 2022**. Note that speakers are only required to prepare a PowerPoint for their presentation on acceptance: full papers are not required.

2 Join a discussion-based workshop

The workshops focus on a specific topic, e.g. application limits at elevated temperatures, welding challenges, ferrite measurements, etc. The theme is explored with discussions supported by panellists who give 10-minute presentations. Please submit your 300 word abstract by **21 February 2022**. Once accepted, panellists need only prepare a PowerPoint.

Deadline: 21 February 2022

SEND YOUR ABSTRACT BY 21/2/2022

Email to Mrs Joanne McIntyre, Seminar Organiser
 Email: j.mcintyre@kci-world.com
 Tel: +31 575 585 298

Showcase your company @ Duplex World 2022

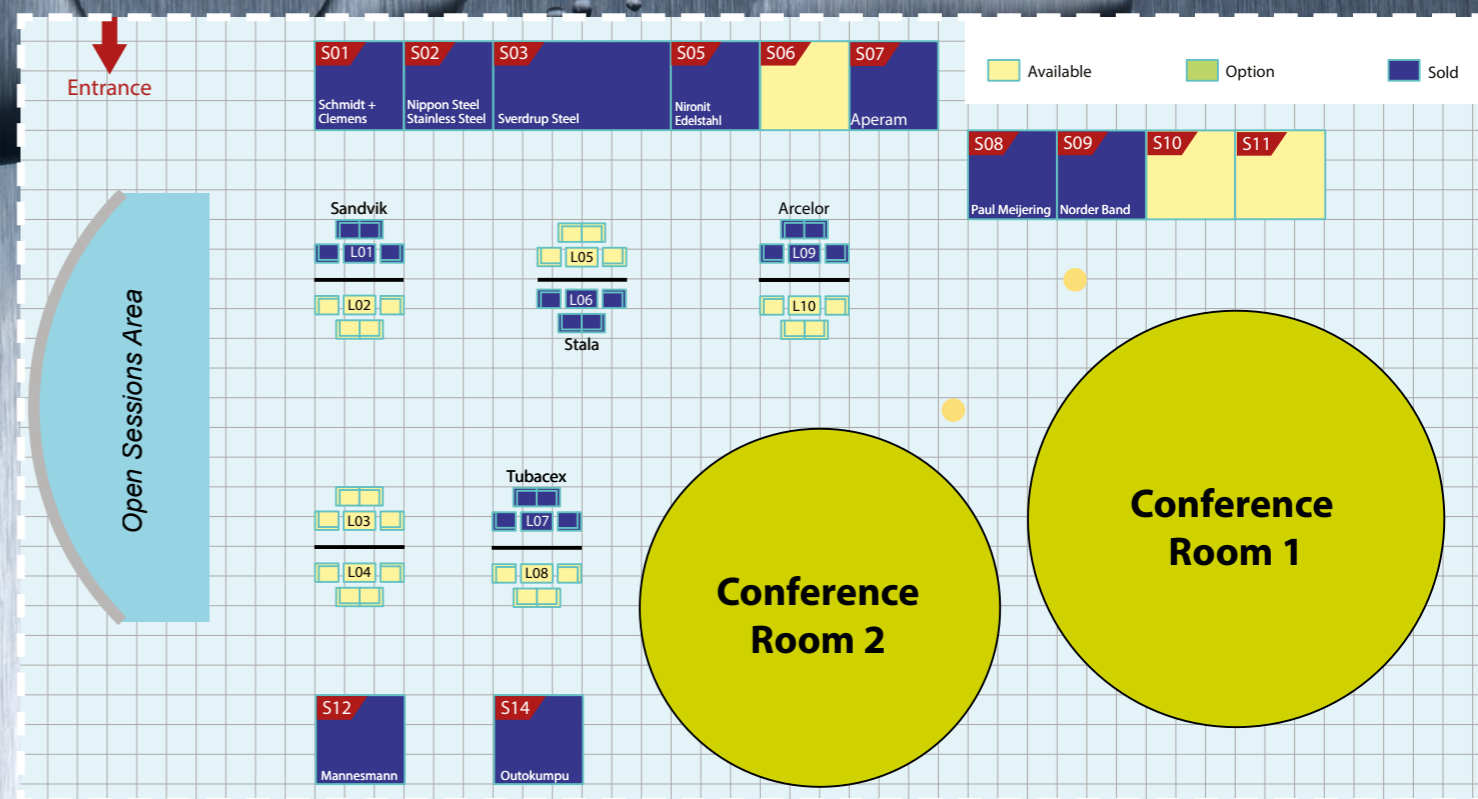

Exhibition Stands

Stands provide an ideal platform to showcase your company products and activities.

Stand packages include stand building, basic furniture, two days catering and conference tickets for two staff members.

**Exhibition Stand
 4,900 Euro**

Why you should exhibit:

- ✓ Highly targeted niche event
- ✓ Strong end-user presence
- ✓ Build a network that will boost your career

To book your Exhibition Stand or Networking lounge, go to www.stainless-steel-world-duplex.com or contact Mr Erik Schoppema email: e.schoppema@kci-world.com Tel: +31 575 585 293

Networking Lounges

Lounges provide an opportunity for companies to network directly with clients and peers in an informal setting ideal for private discussions. Lounges include a couch, chairs, table, back-drop with company logo, two days catering and Seminar tickets for two staff members.

**Networking Lounge
 5,900 Euro**

Sponsored by:

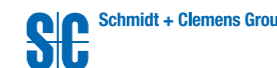

Powered by:



The performance of duplex stainless steels in caustic soda

Caustic soda (NaOH) is widely used in industry, and at lower temperatures and concentrations carbon steel is commonly used. However, at higher concentrations and temperatures the corrosion rate increases, and there is a significant risk of caustic stress corrosion cracking (SCC). In such cases it has been common to switch to nickel alloys, with a significant rise in cost. This paper shows that duplex stainless steels have good resistance to both general corrosion and SCC in caustic solutions over a wide range of concentrations and temperatures. The limits of use and some successful service experiences are presented to show how duplexes may be applied cost effectively.

By Roger Francis, RFMaterials, UK

Caustic soda (NaOH) is widely used in industry for a variety of purposes, including pulp and paper, soap, detergent, catalyst recovery, mineral processing, pH control and many others. As caustic concentrations and temperatures increase, the corrosion rate of carbon steel increases, and also the risk of SCC.

The recommended limits of use to avoid excessive corrosion of carbon steel in caustic soda vary from 50° to 80°C depending on the source¹, but carbon steel is often used at higher temperatures with a corrosion allowance.

The limits of use of carbon steel to avoid caustic SCC are in NACE SP0403 (Figure 1), and it can be seen that the temperatures significantly exceed 80°C where carbon steel is allowed with stress relief². However, there are frequently SCC failures of carbon steel at elevated temperatures and one reason for this is that not all commercial

caustic soda is pure. The most common method for caustic production is the diaphragm process and this will always contain chlorides, typically at around 1% concentration, but individual batches maybe 5 or more times this. The presence of chloride significantly affects the corrosion of carbon steel. In addition, diaphragm grade caustic also contains ~0.3% chlorate, which is an oxidizer and can move the potential to a region where SCC is likely. Caustic soda made by the membrane method contains low levels of impurities, but it is more expensive.

It can be seen in Figure 1 that where carbon steel is not satisfactory, nickel alloys are recommended. The most common ones are alloys 400 (UNS N04400), 800 (UNS N08800), 600 (UNS N06600) and nickel 200 (N02200). This alloy change represents a significant increase in the cost of equipment. What is less well publicised is the fact that duplex stainless steels perform

well in caustic soda, and at lower cost, although they do have limits of use, as is discussed below.

General corrosion

The iso-corrosion curves (0.1 mm/y) for duplex (UNS S32205) and superduplex stainless steel (UNS S32760 and S32750) in caustic soda are shown in Figure 2, along with that for 316L austenitic stainless steel. These were compiled by the author from a number of sources³. One advantage of corrosion in caustic soda is that a change that moves conditions across the iso-corrosion curve does not cause a massive increase in corrosion rate³. For example, this means that a small increase in temperature does not necessarily cause a massive increase in corrosion rate³. Figure 3 shows the effect of increasing chlorate concentration on the general corrosion rate of superduplex and nickel 200 in 50% caustic with 7% NaCl at 100°C. It can be seen that the corrosion rate

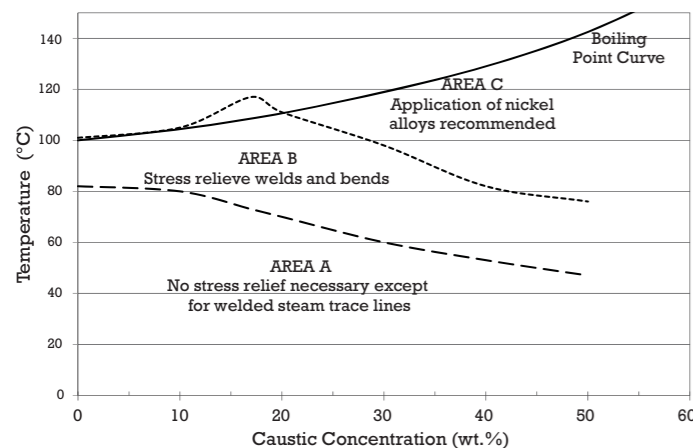

Figure 1. Limits of use of carbon steel in caustic soda to avoid SCC².

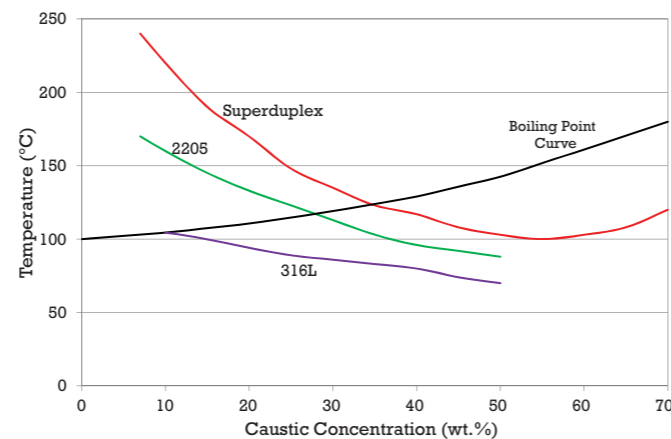

Figure 2. Iso-corrosion curves (0.1 mm/y) for some stainless steels in caustic soda³.

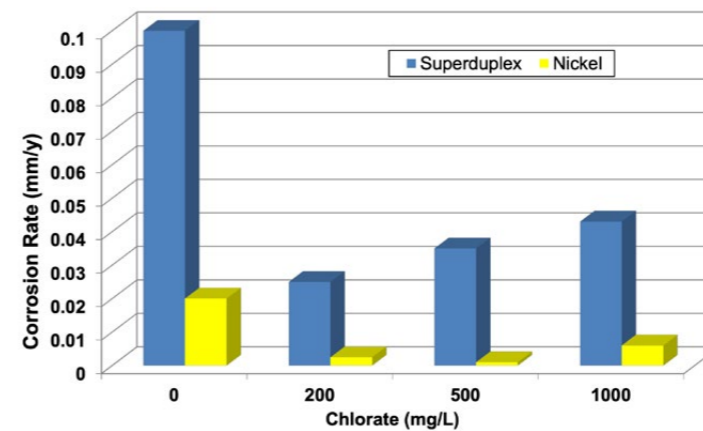

Figure 3. Corrosion rates of superduplex and nickel in 50 wt% caustic plus 7wt% NaCl at 100°C³.

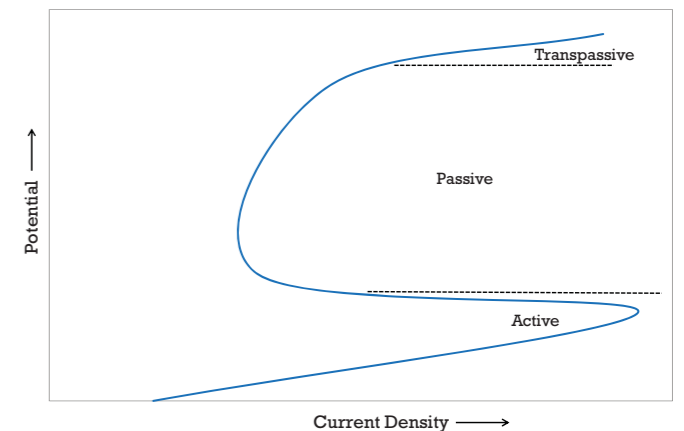

Figure 4. Schematic polarisation curve for duplex stainless steel in caustic soda⁴.

decreases at low chlorate concentrations and then slowly increases with chlorate concentration. This is because of the shape of the polarisation curve for stainless steels in caustic soda, as shown schematically in Figure 4⁴. In 50% caustic at 100°C, superduplex stainless steel is in the active region. Small additions of chlorate move it into the passive region with a lower corrosion rate. The corrosion rate increases with further increase of the chlorate concentration, because the passive current increases as the potential increases (Figure 4). When an alloy is in the passive region, the addition of an oxidizer can move the potential into the transpassive region, with a significant increase in corrosion rate. Although the corrosion rate of nickel was lower than that of superduplex, the corrosion rate of superduplex was still very low, and within normal engineering design values.

Crevice corrosion

Crevice corrosion in stainless steels is caused by a build-up of chloride in the crevice and a reduction in the pH by

hydrolysis, until the depassivation pH is reached. In caustic soda with chlorides, the high solution pH and its diffusion into the crevice prevents a very low pH being reached. Hence, crevice corrosion has not been observed with duplex stainless steels in caustic soda containing chlorides.

Stress corrosion cracking

Duplex stainless steels are very resistant to caustic SCC and none has been seen in 2205 or superduplex in solutions from 5 to 50 wt% caustic at 100 to 250°C under slightly oxidizing conditions³. Even with significant additions of chloride, no caustic SCC was seen under the same conditions. Caustic SCC of duplex and superduplex stainless steel has occurred under oxidizing conditions, as it has for other grades of stainless steel. Clarke reported SCC of 2205 in 15% caustic plus 10% sodium sulphate with 10 bar oxygen at 160°C, but not at 140°C⁵. Unfortunately further data on 2205 in caustic under oxidizing conditions is not currently available.

The author carried out extensive tests on S32760 superduplex with 10 bar oxygen pressure over a range of caustic concentrations and temperatures. The results in Figure 5 show that SCC only occurred over a limited range of concentrations and temperatures. Further tests in 10% caustic with a range of partial pressures of oxygen showed that the threshold for SCC was about 5 bar of oxygen (Figure 6). This enabled a conservative limits-of-use curve for S32760 in oxidizing caustic to be constructed, as shown in Figure 7 alongside the curve for 316L from Sedriks⁵. Many of the applications for duplex and superduplex in caustic soda are under reducing or slightly oxidizing conditions, and SCC failures are rarely seen. Superduplex piping was handling ~7% caustic plus bauxite at around 230°C in an alumina plant and SCC was detected after two years of operation (Figure 8). The conditions were not thought to be oxidizing, but an analysis of the bauxite showed that it contained

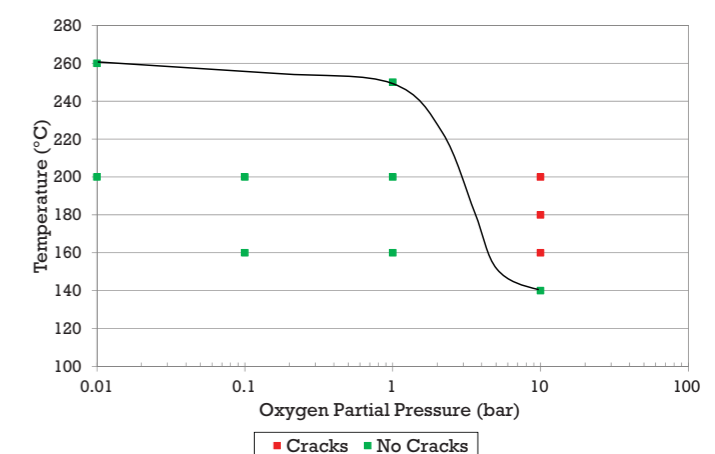
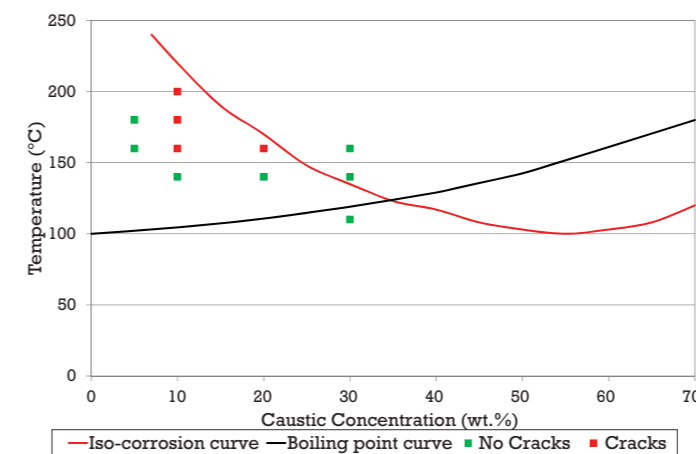

0.5 g/L vanadium, which is a powerful oxidizer in its higher valency states.

Service experience

Duplex (2205) and lean duplex (UNS S32304) have been widely used in the Kraft pulp and paper process for many years with excellent results. The caustic soda is present with a sodium sulphide catalyst, so the conditions are reducing. There have been one or two failures, but these were all on material that was poorly welded or stressed beyond its 0.2% proof stress⁶.

In the petrochemical industries it is common to remove the catalyst from some process streams with caustic soda. The author has seen severe SCC of carbon steel piping and valves in this duty at 85°C, where the 25 wt.% caustic soda was diaphragm grade. A change to 2205 duplex for the pipes and valves solved the problem. Other plants have fitted caustic recovery lines in 2205 duplex from new, with good results.

In some processes it is required to remove impurities from caustic soda by oxidation. Provided this is done at temperatures below the limits discussed above, or less than 5 bar oxygen pressure, 2205 duplex and superduplex have given good service for vessels and piping.

The data and service experience show that duplex and superduplex stainless steels can provide a cost effective alternative to nickel alloys in many applications involving caustic soda.

Acknowledgement

The author would like to thank Rolled Alloys for permission to use

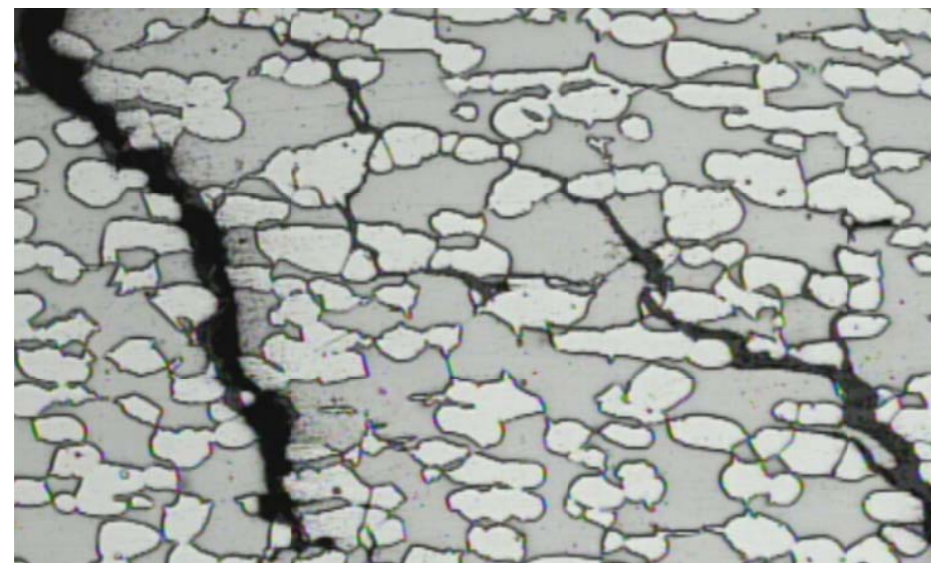

Figure 8. Caustic SCC cracks in a superduplex pipe after two years in ~7% NaOH with 0.5 g/L vanadium at 230°C.

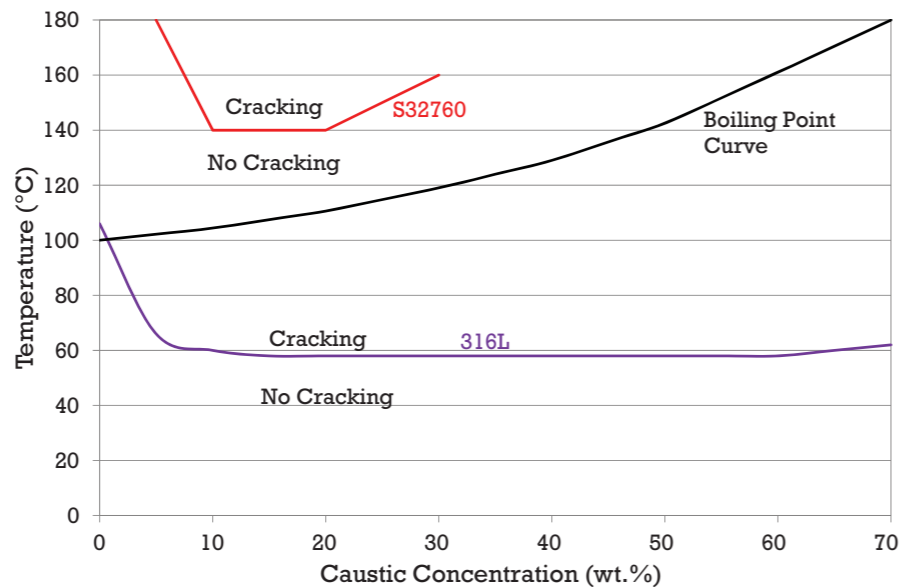

Figure 7. Conservative SCC limits for 316L and S32760 superduplex under strongly oxidizing conditions^{3, 5}.

some of their technical data and the photograph.

References

1. R Francis and S Clarke, *Corrosion in Caustic Soda in Mineral Processing Operations*, Corrosion **76**, 7 (2020) 707
2. NACE SP0403, *Avoiding Caustic Stress Corrosion Cracking of Refinery Equipment and Piping*, 2015, NACE International, Houston, TX, USA.
3. R Francis, *The Corrosion of Duplex Stainless Steels: A Practical Guide for Engineers*, NACE International, Houston, TX, USA, 2018
4. A K Agrawal, K G Sheth, K Poteet and R Staehle, *The Polarization Behaviour of Fe-Ni-Cr Alloys in Concentrated Sodium Hydroxide Solutions in the Temperature Range 25° to 150°C*, J Electrochem. Soc. **119**, 12 (1972) 1637
5. A J Sedriks, *Corrosion of Stainless Steels*, 2nd edition, published by J Wiley and Sons, New York, USA, 1996.
6. D.R. McIntyre and R. Francis (eds), *Environmental Cracking: Guidelines for Preventing Stress-Corrosion Cracking, Hydrogen Assisted Cracking and Liquid Metal Embrittlement in the Chemical Process Industries* (St. Louis, MO: Materials Technology Institute, 2016).

About the author

Roger Francis has been a corrosion engineer for 45 years, with 25 years spent largely on duplex stainless steels. He has published over 90 technical papers, many on corrosion of duplex stainless steels. He has written 6 books and co-edited two more. He has worked extensively in desalination and the corrosion issues that occur in all three types of desalination plant.

He is currently helping to write a guide to avoiding and solving corrosion problems for desalination plant engineers.



Lasers for production optimisation of rolling products

The metal industry, especially the steel industry, faces challenges regarding delivery time, production costs and product quality driven by high requirements from, e.g. the automotive industry. One measure to address these challenges is production automation with a comprehensive understanding of material behaviour under certain control actions in the rolling production lines of long products.

Johann Peters, LAP GmbH Laser Applikationen, Germany

Contactless inline measuring systems play a key role in production optimization. Laser-based systems are the solution for sound information about the product geometry and its surface condition with high accuracy. The detection of deviations of profile and surface, as well as the analysis of its source regarding the caliber is crucial for taking the right control actions in the rolling line. Smart evaluation and data processing allow real time detection of product parameters and the supply of significant details for the process control system and the operator, respectively.

Challenges in hot rolling mills

Hot rolling mills are the last production step to influence the product quality and production costs significantly. Wear, damage, adhesive scale and defects on the rolling caliber as well as production process condition changes like temperature changes, unforeseen production interruptions or strain variation at the caliber influence the quality of the rolled products. The consequences on the rolling product are profile deviations, breakouts, splitting and bursting, dents, scratches and cracks. Tight tolerance demands require the shortest reaction time on production condition changes.

Laser-based solutions

Two contactless laser measuring principles are common for inline

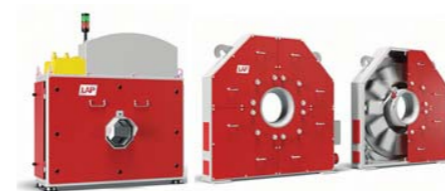
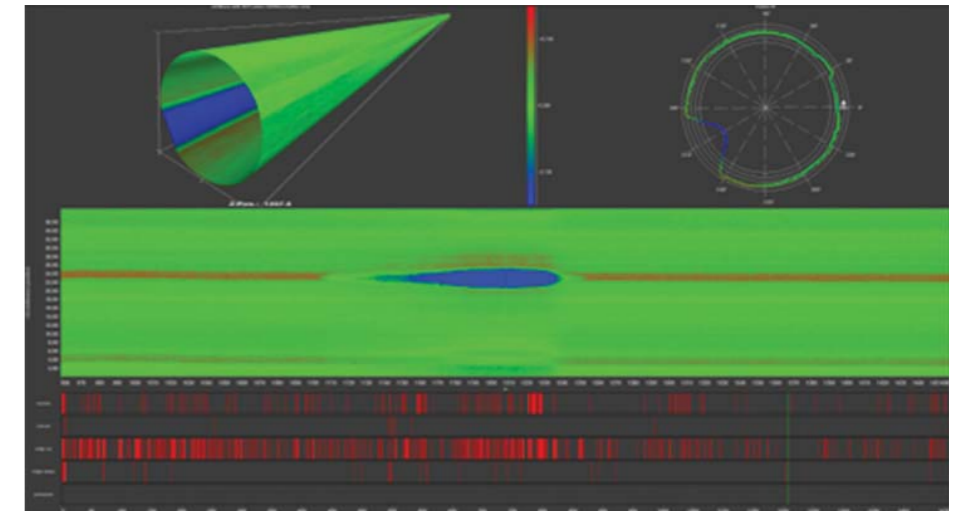

Figure 1: CONTOUR CHECK SHAPE (left), CONTOUR CHECK ROUND (middle), CONTOUR CHECK EDGE (right) system (Picture source: © LAP GmbH Laser Applikationen)



The system offers real-time information for operators in rolling mill plants.

profile measurement systems; the shadowing and the light-sectioning principles. LAP offers profile measurement system solutions with both principles (Figure 1). The newest application is profile measurement in combination with identification of rolling defects and rolling gap, as well as with surface defect detection on rolling products in one single measurement gauge.

Benefits in hot rolling mills

These systems are mainly used in hot rolling mills for long products, rebars and pipes, especially for valuable materials like SBQ (Special Bar Quality) products. LAP's light-sectioning system CC SHAPE can identify and visualize rolling defects regarding the position of the caliber to each other and its filling factor. Especially in wire rod rolling mills with a layer head, the identification of the rolling gap and the relation of the measured information to the gap solves a crucial production challenge. In productions with high material surface requirements, the CC SHAPE

is additionally used for surface defect detection. Surface defects down to 100µm depth or height and 200µm width can be identified over the length of the material. To fulfil industrial requirements for tight production tolerances, closed loop control systems for rolling mills are becoming more important. LAP provides measuring gauges for both feedback and feedforward control with the same real time set-up and defined communication architecture.

About the author

Johann Peters is Product Manager, LAP GmbH Laser Applikationen. He started his career with LAP in 2018 as a product manager

for laser measurement systems in the steel industry. Prior to this, he worked for two years as an application engineer in the automotive industry and spent another two years as a production engineer in the sheet-metal processing industry.



[COLUMN]

Achieving ASTM G48 Corrosion test

Q: I work for a company welding pipeline for the oil and gas segment. On a fairly regular basis, we have difficulty achieving the required ASTM G48 corrosion test requirements of 40°C when welding super duplex stainless steel. We use an SFA/AWS A5.9 ER2594 super duplex filler metal, and we have less than 50% pass rate at 40°C. Do you have any suggestions please?

A: There are a number of suggestions, and they fall into two categories. The first is modifications to the welding process and the filler metal selection, and the second is to improve the test piece preparation.

I will assume that the welder is sticking closely to the welding parameters, that the heat input and interpass temperatures are kept to a minimum, that maximum heat input < 1.5kJ/mm and the

maximum interpass temperature <150°C. The importance of these numbers cannot be stressed enough with super duplex, as the high chromium (25%) and nickel (10%) content will start precipitation of intermetallic phases in a matter of minutes if the temperature is exceeded. These parameters are relevant to both GMAW and GTAW processes. Sigma phase ferrite that has been precipitated in the microstructure will seriously reduce the corrosion resistance of the weld. The ferrite acts as microscopic pockets of weakness because the structure is ferrite in these areas and is no longer a duplex mix of austenite and ferrite with all the inherent mechanical strength and corrosion resistance. If the welding is not an issue, then I would recommend using a super duplex filler metal with a high PRE (pitting resistance equivalent) number. Each manufacturer should be able to supply you with a PRE number for their



Figure 1. Duplex microstructure with an even mix of austenite and ferrite.

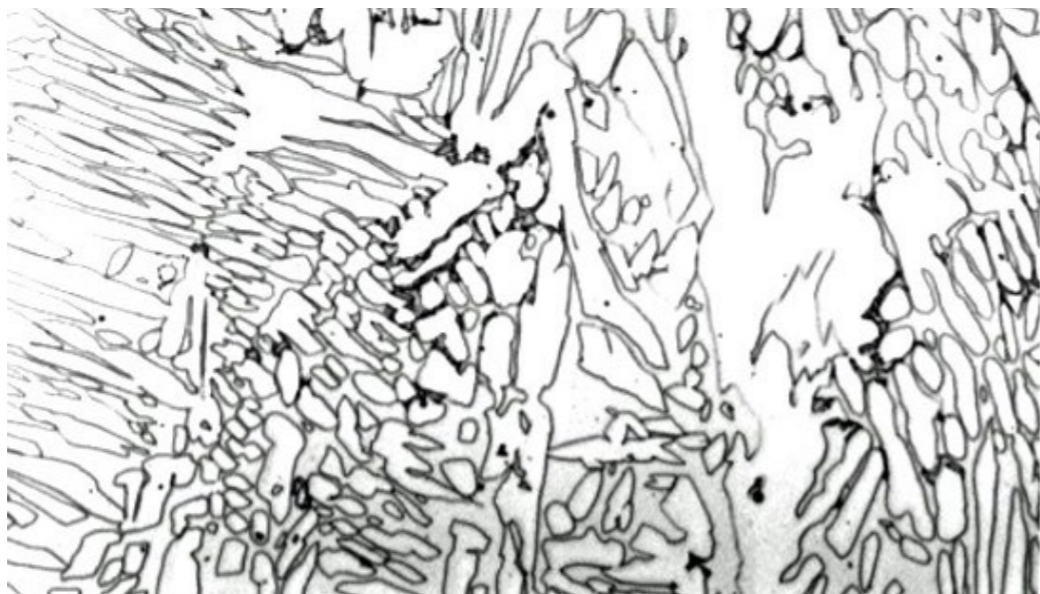

Figure 2. Duplex microstructure with black spots of precipitated intermetallic phases.

Meet the columnist



Peter Stones IEng
MWeld IWE/EWE

As part of the ESAB Specialty Alloys Group, Peter is technical support for stainless and nickel alloy filler metals. Peter is actively involved with TWI and is a non-executive director of The Welding Institute. Peter worked for Sandvik for ten years and was Global Product Manager for Sandvik Welding until 2018 when ESAB purchased the filler metals business. Email: peter.stones@esab.com

at 40°C on super duplex

Pitting potential

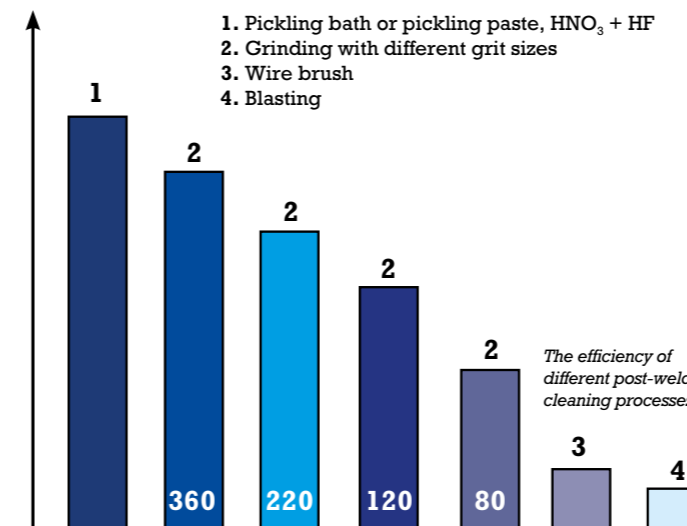

Figure 3. The efficiency of different post weld cleaning processes on the pitting potential.

products, and in any event, the number can be calculated from the composition supplied on the datasheet using the formula:

Pitting Resistance Equivalent (PRE) = %Cr + 3.3x%Mo + 16x%N

Remember to use the minimum percentages in the formula as a worst-case scenario. ASME Section II Part C has a minimum requirement of 40 for the PRE for the super duplex grade. However, there are products on the market with a PRE = 42.5, so using one of these would give you a little advantage. If permitted within the client's specification, another solution would be to overmatch the filler metal and use a **hyper duplex** grade. This grade has a PRE = 49, and G48 corrosion tests have been achieved in excess of 60°C. The preparation of the test piece after welding

is also crucial to the corrosion resistance. Very basic procedures such as removing any sharp corners (and indeed machining them smooth) will make a big difference; again, check whether it is permitted within the client specification. The following graph illustrates the efficiency of different post-weld cleaning processes on the pitting potential of the weld. The more highly that you can polish the test piece, the higher the ASTM G48 temperature it will be able to achieve. The best results will be obtained with pickling. In the oil and gas sector, the requirements for the ASTM G48 corrosion test temperature for super duplex changed about ten years ago. Prior to that, the requirement was for 30°C and was not really an issue. The increase to 40°C is still causing some issues, as you are experiencing, but it is quite achievable. Please feel free to contact me for a more detailed discussion.

Free newsletters for your sector

Did you know that in addition to Stainless Steel World magazine, KCI Publishing also produces free email newsletters? Visit www.kci-world.com/newsletters to subscribe.

Stainless Steel World Newsletters

- Global News update
- Duplex update
- Nickel update
- Americas News update
- India & Middle East
- Edelstahl Aktuell (German)

Valves & flow control newsletters

- Valve World
- Fugitive Emissions
- Actuation Update
- Valve World Asia
- Valve World India & Middle East
- Valve World Americas Noticias de Válvulas (Spanish)
- Valve World Brasil (Portuguese)
- Armaturen Welt (German)

Other newsletter subjects

- Hose & Coupling World
- Heat Exchanger World
- Pump Engineer

TO SUBSCRIBE VISIT
WWW.KCI-WORLD.COM/NEWSLETTERS

SUBMIT YOUR PRESS RELEASES TO
PRESS.SSW@KCI-WORLD.COM



Experimenting with welding superduplex without filler metal

Duplex and superduplex stainless steels are commonly welded with filler metals to obtain sound welds with good mechanical, metallurgical and corrosion resistance properties. Filler metal addition and heat input control are important factors to consider, but the diameter and thickness of the pipe must always be considered as main parameters. This study takes a closer look at the welding of small diameter and 'thin' wall thickness superduplex pipes with orbital GTAW, without filler metal, using an orbital closed head welding machine.

By Loïc Amadu, Welding Engineer, Friedlander Contracting International Ortec Group

When a pipe presents a thin wall thickness and small diameter, the heat diffusion during the welding process can be very weak. This weak diffusion leads to 'slow' cooling (regarding welding), and thus more austenite germination. If Ni-sur-allied filler metal is added on the welding pool, austenite germination can happen at a faster rate, thanks to the Ni gamma effect. The combined effects of a weak diffusion and the Ni-sur-allied filler metal lead to easy austenite germination (i.e low ferrite content) in the weld metal after welding. In order to obtain an acceptable ferrite content (35% to 65%) in the weld metal, some welding joints can be performed without filler metal, using an orbital GTAW closed head welding machine.

In addition to diameter and thickness, some other parameters/welding difficulties must be taken into account:

- Edge preparation and fit-up;
- Welding position 5G (up and down) and welding pool with relatively low viscosity (gravity effect);
- Pitting Resistance Equivalent Nitrogen (PREN = Cr + 3.3Mo + 16N), mainly of root pass, limitation/absence

- of secondary austenite (corrosion resistance);
- Time elapsed within the range 600°C-1000°C (carbide, nitride, sigma phase);
- 'Low heat input' necessary due to thickness and diameter;
- Residual magnetism on the pipe (arc blow); and,
- Monitoring of welding parameters.

The experimental setup

A full Welding Procedure Qualification Record (WPQR) was performed to qualify the welding of S32750 19.05/2.41mm pipe. 8 welds were performed using welding machine and instrumentation as follows:

- Polysoude PS164-2 orbital GTAW generator (figure 1);
- Polysoude MW40 orbital GTAW closed head (figure 2); and,
- Swagelok SWS internal purge pressure kit (figure 3).

The edge preparation and welding details included:

- BW square edge (by machining) without gap (figure 4);
- 5G (up and down) position (figure 5);
- No filler metal;
- GTAW orbital welding;
- 1 pass (figure 5);
- 98% Argon + 2% Nitrogen (shielding and backing gas); and,
- Tungsten electrode WTh20, 1.6mm, taper angle 60°, tip 0.5mm, arc gap 1.3mm (figure 6).

For each weld, full monitoring was completed. Important welding parameters to consider included:

- Pipe preparation (square edge, no gap, clean inner and outer surface);



Figure 1: PS164-2 Polysoude.

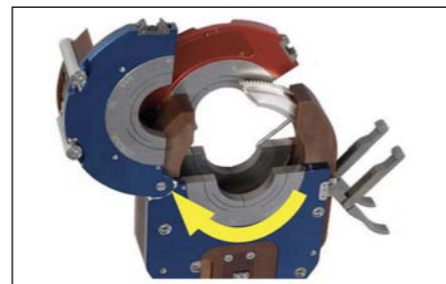

Figure 2: MW40 Polysoude.

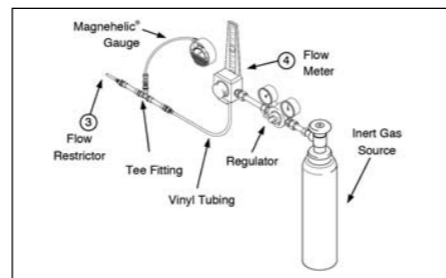

Figure 3: SWS internal purge pressure kit Swagelok.

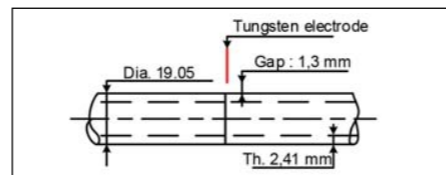

Figure 4: Welding preparation.

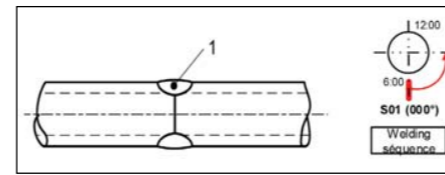

Figure 5: Welding sequence.

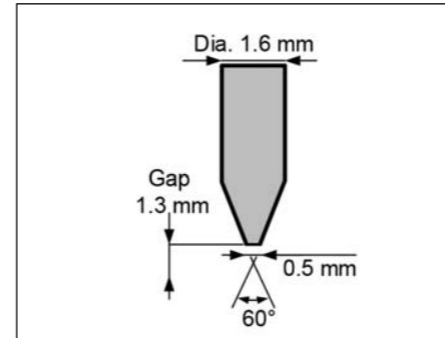

Figure 6: Tungsten electrode preparation.

- Tungsten electrode geometry (type, diameter, angle, tip);
- Internal pressure;
- Shielding and backing gas;
- Gas composition and flow rate;
- Oxygen content (<30ppm inside the pipe);
- Preheat time (welding pool germination) and current;
- Pulsed current (peak and background current and time);
- Travel speeds (peak and background);
- Voltage (arc gap);
- Down slope time; and,
- Heat input.

Non-destructive and destructive (mechanical, corrosion, metallurgical) tests were performed on the welds to meet industry standards. On each weld, the following NDT was performed: visual testing VT with control of maximum underfill at 12h; penetrant testing PT; radiographic testing RT (X-rays); and, ferrite content on weld metal and base metal (with feritscope), each 90° around the pipe.

On the whole welding package, destructive testing was performed as well, such as: tensile testing (x2 whole pipe section); bend testing (x2 root and x2 face at 1h30, 4h30, Th30 and 10h30); hardness testing HV10 located at root, middle and capping in base metal, HAZ (heat affected zone) and weld metal (x2 at 6h and 12h); ferrite content testing located at root, middle and capping in HAZ and weld metal (x2 at 6h and 12h); macrographic testing (x2 at 6h and 12h); micrographic testing (x2 at 6h and 12h); and, corrosion testing (x1).

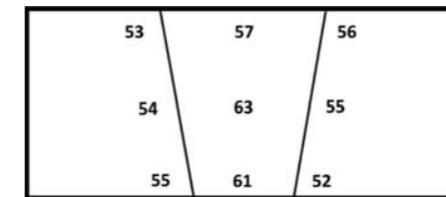

Figure 7: Ferrite content ASTM E562 at 12h.

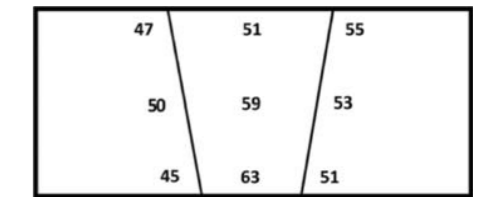

Figure 8: Ferrite content ASTM E562 at 6h.

The experimental results

The NDT and destructive testing results are presented hereafter.

Visual testing results: no indication found by visual testing, the maximum underfill at 12h is less than 0.2mm.

Penetrant testing results: no indication found by penetrant testing.

X-rays radiographic testing results: no indication found by radiographic testing.

Ferrite content (with feritscope) testing results: all ferrite contents on base metal and weld metal are within the range 35% - 65%.

Tensile testing results: tensile strength values of 1052 and 1142 MPa, fracture location on weld metal (acceptance criterion: 750 MPa).

Bend testing results: no indication found both on face and root bend testing.

Hardness testing results: the maximum value of hardness testing in base metal, HAZ and weld metal is 280 HV10 (acceptance criterion: 350 HV10).

Ferrite content testing results: all ferrite content on HAZ and weld metal are within the range 35-65% (figures 7 and 8).

Macrographic testing results: no indication found by macrographic testing. There is no underfill at 6h and the maximum underfill at 12h is 0.16mm (WT is kept thanks to root penetration – figure 9).

Micrographic testing results: no indication found by micrographic testing (absence of nitride, carbide and intermetallic phase - figure 10).

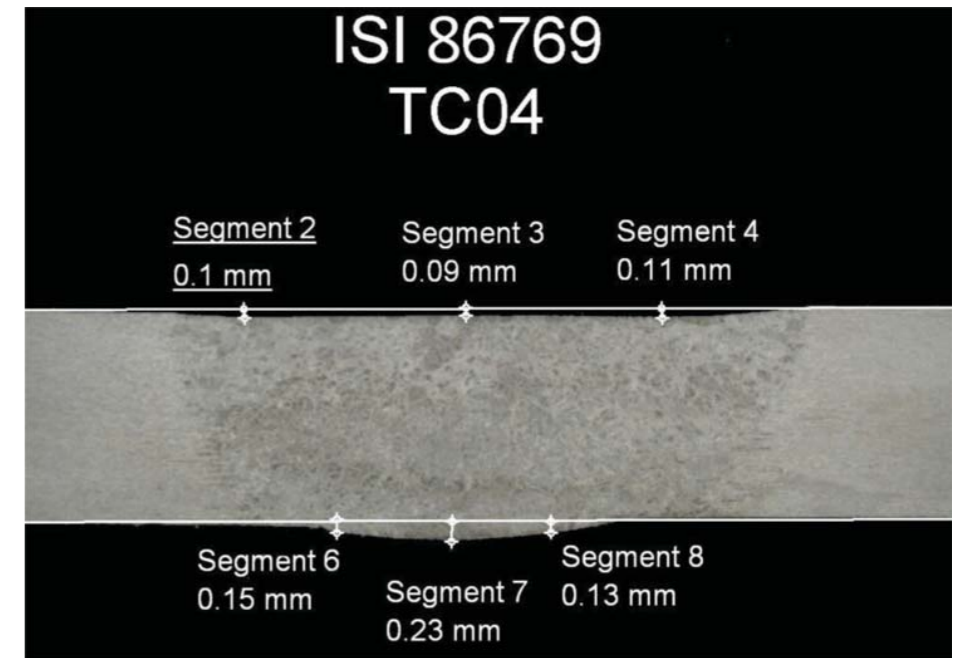

Figure 9: Macrography at 12h.

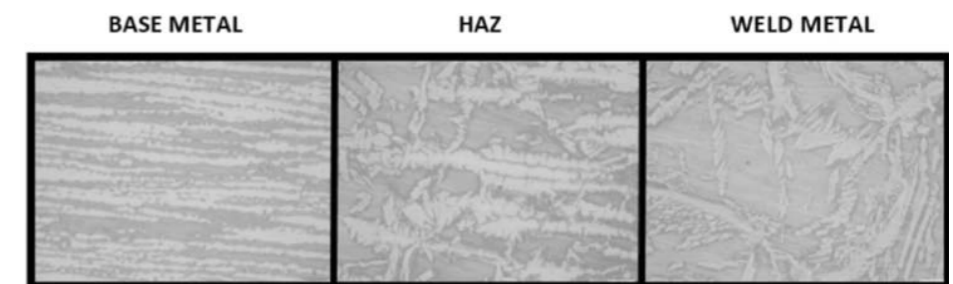

Figure 10: Micrography of base metal, HAZ, weld metal at 12h.

Corrosion testing results: test conditions included pickling 5min HF 5% + HNO₃ 20%, 60°C, air passivation 96 hours, and ASTM G48 method A corrosion test 24h, 40°C. There was no pitting and no weight loss.

Conclusions

All non-destructive, mechanical, metallurgical and corrosion testing were satisfactory. A maximum underfill less than 0.2mm is located at 12h, but the root penetration compensates this underfill.

A lot of welding parameters (pulsed current, arc voltage, welding speed, sectors, downslope) and welding difficulties (edge preparation, fit up,

pressure purge, welding position, underfill) can be managed to obtain a sound weld. Therefore, a lot of preliminary welding trials must be done before the beginning of the WPQR.

The main challenges of the welding without filler metals are the limitations of underfill at 12h, and obtaining a ferrite content within the range 35%-65%, both in weld metal and HAZ. The use of internal purge pressure kits helps to manage both root penetration and underfill. The cooling rate and heat input must be under control to manage ferrite content, nitride, carbide, and sigma phase.

Welding with only one pass leads to the absence of secondary austenite, limitation of time elapsed within the range 600°C-1000°C, and optimization of corrosion resistance. The use of an orbital welding machine with closed head leads to good monitoring, control of welding parameters, and good shielding gas protection. The edge preparation and fit-up without gap leads to an optimized backing gas protection with very low oxygen content (nearly 0ppm). Residual

magnetism shall be verified before welding to prevent arc blow. If the residual magnetism is above 2-3 Gauss, the magnetism shall be removed. Welding superduplex without filler metal is possible, particularly on thin WT and small pipe diameter, but must be used with care.

About the author

Loïc Amadu is a Welding Engineer at Friedlander Contracting International ORTEC Group. He is 36 years old and he love his work, as he can learn new things and meet interesting people every day. His scope of work includes welding technical support for oil & gas projects and subsidiaries in Africa, and a welding referent for technical discussions with clients and suppliers.



Contact:
Email: loic.amadu@ortec.fr
LinkedIn: <https://www.linkedin.com/in/lo%C3%A0fc-amadu-b2580071/>
Phone: 0033 6 34 63 76 98

Acknowledgements

The author wishes to express his appreciation to Mr. Jean-Christophe Langan, (jean-christophe.langan@ortec.fr), Welding Engineer, Friedlander Ortec Group, and Mr. Pascal Pattyn, (pascal.pattyn@ortec.fr), Welding Engineer, Friedlander Ortec Group, for their help on this study.

MEET THE DUPLEX WORLD 2022 SPONSORS



Mannesmann Stainless Tubes (MST) is proud of its commitment to the

continuous innovation and development of its production range to support the most demanding of customer needs, across the global market. At the foundation of the company's reputation is its commitment to quality and integrity. MST serves diverse markets, including the Oil & Gas, Power and Aerospace sectors. MST's product range is from 1.6 mm (0.063") to 280 mm (11") outside diameter across the full range of seamless austenitic stainless and Nickel alloy grades, complemented by super-austenitics like 904L and 6Mo, duplex and super duplex alloys, and a complete family of Nickel alloys.



Outokumpu creates advanced materials that are efficient, long lasting and recyclable

– helping to build a world that lasts forever. The cornerstone of its business is enabling growth and innovation through environmentally, economically, and socially sustainable stainless steel products. Its history goes back to the invention of steel and we continue to drive stainless steel innovation. Duplex stainless steel was developed by Outokumpu more than 80 years ago. Since then the company has produced more than half the world's consumption of duplex. Outokumpu duplex stainless steels offer an excellent combination of strength and corrosion resistance. As a result material thickness and costs can be reduced significantly in a wide range of applications.



Sandvik is setting industry standards with its next level, high-performance materials to help meet new operational demands

brought about by extreme water depths below 10,000 ft. (3,000 m) and temperatures above 400 °F (204 °C). Its advanced corrosion-resistant alloys offer increased reliability and enhanced corrosion resistance for the harshest conditions while reducing environmental impact. As a world-leading developer and manufacturer of advanced stainless steels and special alloys, its material solutions contribute to productivity, process reliability and cost-efficiency. Sandvik's range of high-performance tubular materials includes SAF 2205™+, a duplex stainless steel optimized to withstand extreme corrosion, with a high resistance to stress corrosion cracking (SSC), and certified for the latest subsea requirements.



The name Schmidt + Clemens has stood for high-quality special steel solutions for more

than 140 years. The Group is a privately owned German manufacturer of specialised alloys and components, supplying to the petrochemical, separation technology, power technology and industrial furnace construction industries. Known as a consistently reliable business partner, Schmidt +Clemens products are exported to over 85 countries.

Ongoing investments in R&D as well as its people, ensure that the company works according to the latest technical standards. Schmidt + Clemens uses this as a basis to continually improve its products to suit its customer needs.



The TUBACEX Group is a leading company in the supply of seamless stainless steel and high alloy tubular products. With production plants in Spain, Austria, Italy, the United States, India and Thailand, a global distribution network and a worldwide sales presence, TUBACEX has the most extensive portfolio in

the market, covering a wide range of services from design to installation and maintenance operations. The TUBACEX team believe in open innovation as a tool to turn the most demanding needs into tailor-made solutions of high technological value developed in co-creation with customers. This is possible thanks to the company's market knowledge and product performance, as well as its command of the technological processes.

Conquer the globe with Stainless Steel World!

For over thirty years, Stainless Steel World has expanded its global community of manufacturers, suppliers, distributors and end-users. As the most high-profile and respected brand in the corrosion resistant alloy sector, it's the perfect platform to showcase your company's expertise to the world.



The powerful Stainless Steel World brand is an innovative and flexible tool providing tailor-made media campaigns and targeted contact points for all players in the stainless market. The brand combines influential in print publishing, face-to-face events, online news, technical archives and social media channels.

With a reputation for high quality, technical content, Stainless Steel World magazine is the leading technical publication for our industry. Our professional team of editors will prepare a cover story that will bring your company to a vast, global audience through print, online, and social media platforms.

The Stainless Steel World events in Europe, Asia and the US connect end-users, fabricators and suppliers with manufacturers and distributors. The high quality, technical conferences feature the world's leading materials experts sourced from end-users, researchers, and leading manufacturers. The exhibition features the important players in the corrosion resistant alloy sector and connects them with new and existing customers

Wherever you want to do business in the world, Stainless Steel World will take you there.

www.stainless-steel-world.net

JOIN OUR SPONSORS!

To learn about sponsorship opportunities at Duplex World 2022, please contact Mr Erik Schoppema, Tel: +31 575 585 293, Email: e.schoppema@kci-world.com

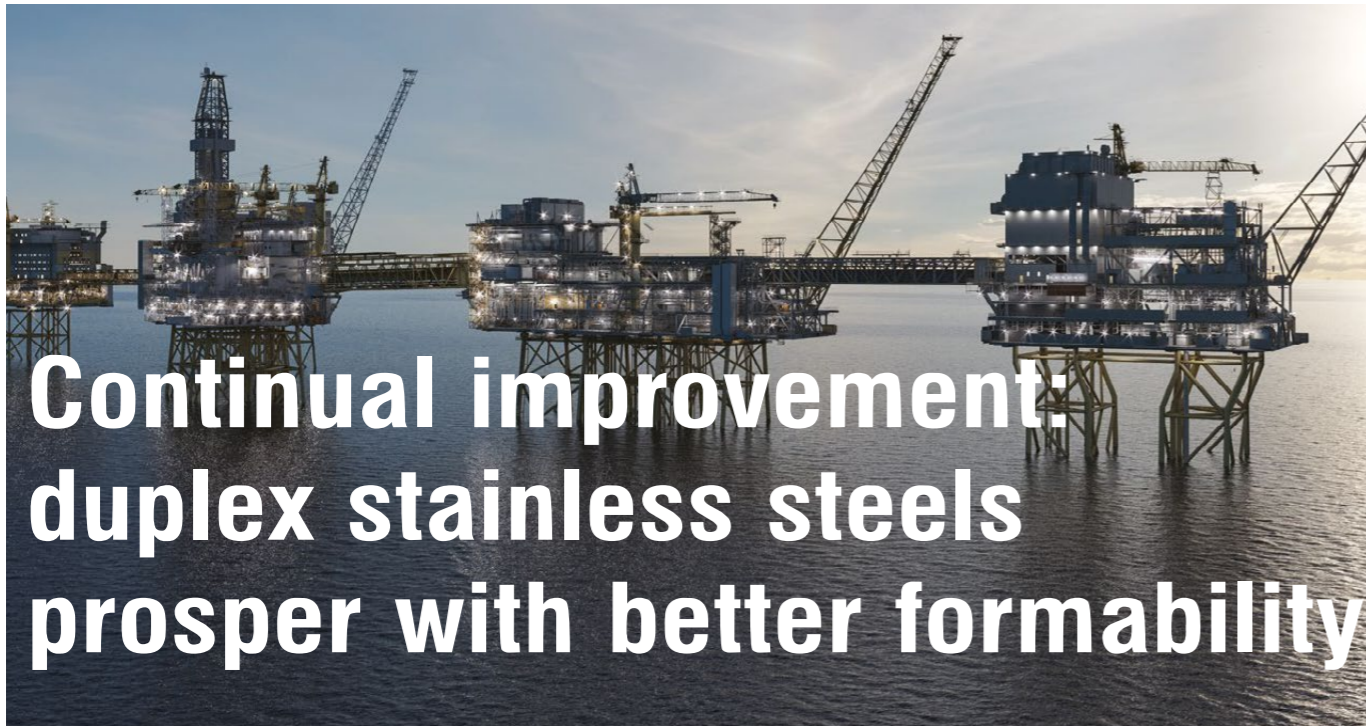

Continual improvement: duplex stainless steels prosper with better formability

This year duplex is celebrating its 90th birthday, albeit in very trying circumstances. The sector has been badly affected by the Corona virus, though some markets are performing better than others. Despite setbacks earlier this year, the oil & gas industry is recovering, and new forming techniques – and especially powder-based additive manufacturing methods – make duplex an increasingly attractive alternative to other grades.

By James Chater

Four ages

We are well into duplex's fourth age: that of better formability. Since the 1930s, when Avesta Ironworks (later Outokumpu) in Sweden started making castings, bar and plate for the pulp & paper industry, duplex has greatly expanded its range and offer. In the 1970s and 1980s, carbon content was reduced and nitrogen added to prevent cracking. The third age was that of expansion: first came the higher-alloyed grades of super duplex and hyper duplex for severely corrosive conditions in chemical, oil and gas and other industries; then came lower-alloyed lean duplex grades, used in storage tanks and other structural and other lower-corrosion environments. Finally, we are far advanced into duplex's fourth age, that of better formability. New grades such as Forta FDX 25, Forta FDX 27 and NSSTS2351 offer improved formability and weldability, making them attractive alternatives to austenitic grades (1).

Powder-based AM

This fourth age has gained a new impetus thanks to powder metal additive manufacturing technology. In metal fabrication, AM (aka 3D printing) affected titanium and nickel forming

early on, leading to a revolution in the manufacture of aerospace components and prosthetics. Now duplex grades are being sucked into this revolution, with profound implications for the oil & gas, petrochemical, pulp & paper,



Vessels, tanks and columns by Butting.



Additively manufactured pumps from KSB.

construction, desalination and water/wastewater industries. A prime example of this is Sandvik's gas-atomized metal powder specially designed for AM. The Swedish company partnered with Renishaw to develop Osprey® 2507-AM super-duplex powder to 3D-print components cater for the offshore oil & gas industry. The material was used on impellers that were 3D-printed for Norway's state oil and gas company Equinor Sandvik. These impellers are faster, lighter and more economic to produce. AM thus has the potential to transform the manufacture of valve and pumps designed to withstand severe conditions. For this reason, the KSB Group has set up a new consulting and testing centre for AM at its Pegnitz location. It has so far tested 300 alloys in the areas of cast iron, unalloyed steels, bronze, stainless steels and duplex steels.

Oil & gas

The opportunity to make components more cost-effectively is a boon for the oil & gas sector at a difficult time. Even before the corona virus, the sector was struggling with oversupply issues. As a result of the pandemic, the oil price fell precipitously, at one point turning negative. The sector has since bounced back, but its future fortunes are hard to predict, as they depend on the vicissitudes of the economy and the growth rate of renewables. Several recent orders suggest that duplex is in high demand and that, despite the

sector's difficulties, oil & gas is still a key market for duplex (Table 1).

Other corrosion applications

Because of its strength and corrosion/erosion resistance, duplex is in demand for a number of industries, from wastewater/desalination, chemical tankers, sugar and pulp & paper. This last is proving surprisingly resilient despite the onset of the digital age. The sector is flourishing, mainly because of the demand from packaging, itself stimulated by the rise in online shopping. Also, the banning of single-use plastic products has led to a surge in demand for paper and cardboard. Two recent orders for

duplex grades in the last year have occurred. Butting supplied vessels and apparatus made from 365 tons of 1.4462 duplex for a flue gas cleaning plant in a pulp & paper mill in South Africa. This was built to a new complex design, not the traditional cylindrical one. Secondly, Miller Mechanical Services delivered a custom-made duplex steaming vessel in 2205 duplex to a facility in Georgia, USA. Waste-into-energy systems require strongly corrosion-resistant materials. GPI supplied four tanks in lean duplex grade LDX 2101 for a project in the Netherlands. These convert chemical waste into steam which is then used to power the plant. Duplex is frequently used for chemical storage and transport. Outokumpu recently supplied 65 tonnes of Forta DX 2205 hot rolled sheets and coils for Rotterdam-based Gpi, who were building a massive tank, 19 metres in diameter and 18 meters in height, for Dow Chemical. In the cargo tanks of sea-borne chemical tankers, duplex is now standard. A recent example is the series of four tankers ordered by Utkilen. The Utkilen T32 design is an ice-class chemical tanker with cargo tanks in duplex stainless steel. Tankers for road transportation are also sometimes made of duplex stainless steel. They are favoured for the transport of LPG as their lower thermal expansion coefficient compared to austenitics means the tanks will not buckle when the pressure drops and the temperature rises.

Table 1. Recent duplex orders in the oil & gas sector

Operator	Materials supplier	Description
Equinor	Butting	2,000 super-duplex spools for pipelines in the FPSO's sulphate removal unit of the Johan Castberg project.
Libra	Sandvik	Prysmian Group to supply SAF 2507® super-duplex umbilicals for Brazil's pre-salt Mero oilfield.
Aker	Sverdrup Steel	316L, lean duplex, duplex and super duplex in plates, bars, and profiles for the HOD field in the Norwegian sector of the North Sea.
OceanTools	Proeon Systems	Deepwater subsea housings in super-duplex
		2205 duplex for gas pipelines in the Tarim Basin of Xinjiang, China.
Libra consortium (Petrobras)	Orseal	Super-duplex valves for FPSO Guanabara MV31 in Mero field.
	PJ Valves (PJV)	Valves in carbon stainless steel, duplex and Inconel clad material for FPSOs in Brazil, Mexico, and Nigeria.
	Amarinth	API 685 Magnetic Drive horizontal pump in super-duplex delivered to Sensia for an oil rig in the Norwegian North Sea.



Orseal super-duplex valves are used on FPSOs in the offshore oil & gas industry.

Power generation

Stringent pollution abatement rules are stimulating demand for duplex stainless steel in fossil fuel stations and on ships. Flue gas desulphurization (FGD) units remove compounds such as sulphur dioxide, carbon dioxide, dust and soot. For these, super-duplex grades are ideal. Duplex is also finding a relatively new use in the fasteners of wind farms. Belgian producer BUMAX supplied

corrosion-resistant, high-strength studs in SDX 109 for a wind farm off the Belgian coast. The studs fasten the wind turbine generator external platform to each of the 23 wind turbine foundations. The same product was used in the upgrade of CERN's Large Hadron Collider (LHC) particle accelerator. The studs are extremely strong and can endure temperatures down to -271.3°C (absolute zero).

Construction

Architecture & construction has suffered along with the rest of the economy, but some sectors are more badly affected than others. The emptying of offices and hotels has dented the appetite for new ones, but affordable and suburban housing is faring better, at least in the USA (2). Duplex 2205 and lean grade LDX 2101 are frequently used in bridge construction. Aesthetic and practical considerations (life-cycle costs, strength-to-weight ratio) led designers of two Swedish bridges, at Sölvesborg and Södertälje, to specify LDX 2101. Duplex is often specified as rebar in bridges and other structures.

Conclusion

In those industries that are thriving, duplex stainless has a bright future, thanks to recent advances in formability and weldability that make it a more attractive than austenitic grades in a number of applications. In some cases, the newer grades permit the development of more efficient designs of tanks and vessels.

References

- (1) <https://www.outokumpu.com/en/expertise/2020/duplex-90-years/history-of-duplex-stainless-steel>.
- (2) <https://www.fastcompany.com/90539820/covid-19-is-crushing-the-architecture-industry-but-not-in-the-ways-you'd-expect>



BUMAX's super duplex (1.4410) stainless-steel fasteners are used in wind power farms and on the CERN LHC particle accelerator in Switzerland.

Formula to convert Rockwell & Vickers hardness scales for duplex stainless steels

Historically there has been no reliable conversion formula for the Rockwell C and Vickers hardness scales for duplex stainless steel grades. However, a recently completed study has successfully evaluated and documented the correlation between the two scales.

By Yong Joo Kim, Webco Industries, USA

Hardness conversions between the Rockwell C and Vickers scales are different for duplex stainless steels as compared to carbon or other low-alloy steels. A proper conversion is an important consideration when hardness value limits from industry standards in Rockwell C are applied for product or weld qualifications and production testing, all of which are typically conducted using the Vickers micro-hardness value. Various organizations recognize the need to find the accurate correlation and development of a proper conversion table. However, there is no reliable hardness conversion formula for these two hardness scales for duplex stainless steel grades. The conversion table in ASTM E140 for carbon steel is inappropriate for duplex steels; there have been limited studies, and therefore no meaningful data is available. This study was designed to evaluate and document the correlation between the Rockwell C and various Vickers scales. Tests were performed using UNS S32101, S32205 duplex and S32760 super-duplex stainless steel with various amounts of cold-worked material in strip form. Different testing method options were evaluated to define the proper methodology and improve the reliability of the conversion between the two methods. Results documented in this experiment are summarized by the Rockwell C scale to the Vickers scale.



Yong-Joo Kim, VP Process and Product Innovation, Webco Industries, Inc.



Daniel Eyzop, Research Engineer, R&D Physical Metallurgy, Outokumpu

Study Summary

1. Material

Three different types of duplex material were selected as a product form of hot rolled and solution annealed strip with chemical compositions as shown in Table 1. A section of the strip for each grade was further processed by cold rolling to increase the hardness by work hardening. The target amounts of cold working were 0% (hot rolled & solution annealed), 5%, 10% and 15% to generate four hardness groups for each grade. After final cold rolling, study samples were cut from the middle of the processed strip to eliminate any inconsistency from the edges.

2. Measurement methodology

Indentation size or volume factor: A smaller impact can be more sensitive to the position of the impact in relation to the microstructure. If ferrite is not homogeneously distributed, HV0.5 can cover less while HV20 covers several lamellas. An analysis was performed and the mean hardness data showed 3 HV differences between Vickers load ranges. This is considered as a homogeneous microstructure with a minimum volume effect for the study. **Surface hardening factor:** During the polishing process of the mounted sample for the Vickers hardness testing, work hardening may occur at the thin surface layer depth. For the Rockwell C hardness testing, either 'as-is condition

Table 1. Chemical compositions and ferrite % of samples

UNS Grade	Chemical Composition %											Ferrite %
	C	Mn	P	S	Si	Ni	Cr	Mo	N	Cu	W	
S32101	0.018	5.02	0.024	0.001	0.66	1.6	21.4	0.3	0.23	0.36	-	45%
S32205	0.016	1.34	0.028	0.001	0.35	5.8	22.2	3.2	0.17	-	-	45%
S32760	0.017	0.66	0.024	0.001	0.30	6.8	25.4	3.5	0.29	0.55	0.63	43%

coupon' or 'mounted and polished' option was considered. For the selection of the sample preparation for Rockwell C hardness, an experimental test was performed. The result indicated that a 'mounted & polished' condition has a work hardening effect of 0.9 HRC compared to the 'as-is condition coupon' and % RA improves from 1.4% to 0.8%. To eliminate surface hardening from the effect of the cold rolling operation, all samples are mounted revealing the cross section and Vickers hardness is measured at 10% of the surface depth location.

Magnification factor: For the indentation measurement of the Vickers hardness by the light microscope, ASTM E92 recommends objective magnification size based on the diagonal length. For the selection of the magnification, 20X objective for HV0.5 scale, 50X objective for others was considered. To review the differences, a study was performed and the result indicated that the mean HV0.5 hardness by "50X Objective" was 8 HV higher than the "20X Objective". The % RA was almost the same; 1.8% vs. 1.9%. To minimize the possible magnification variation, "20X Objective" is selected to test all Vickers scales.

3. Sample preparation

The original sample coupon size was approximately 70 mm by 70 mm and this was cut into four sections using a cold saw to prevent any heat during cutting. Each sample was marked with the location and the direction of rolling. For consistency of the sample preparation, all samples were prepared at one laboratory using the same procedure, lab equipment and technician. All samples were cut to the same size as a flat specimen shape and mounted in epoxy then ground and polished with three-micron diamond paste. After polishing, the samples were not etched, and the finished specimen surface was examined for any imperfections. Rockwell C hardness samples were 30 mm by 30 mm in size and were mounted and polished from the top surface, while Vickers hardness samples were 30 mm by 5 to 6 mm in size and were mounted and polished from the cross-section surface to reveal a rolling direction cross-sectional view.

4. Testing procedure

The testing instrument was calibrated and verified using a reference test block prior to testing.

Rockwell C hardness testing: From the epoxy mounted samples, hardness was

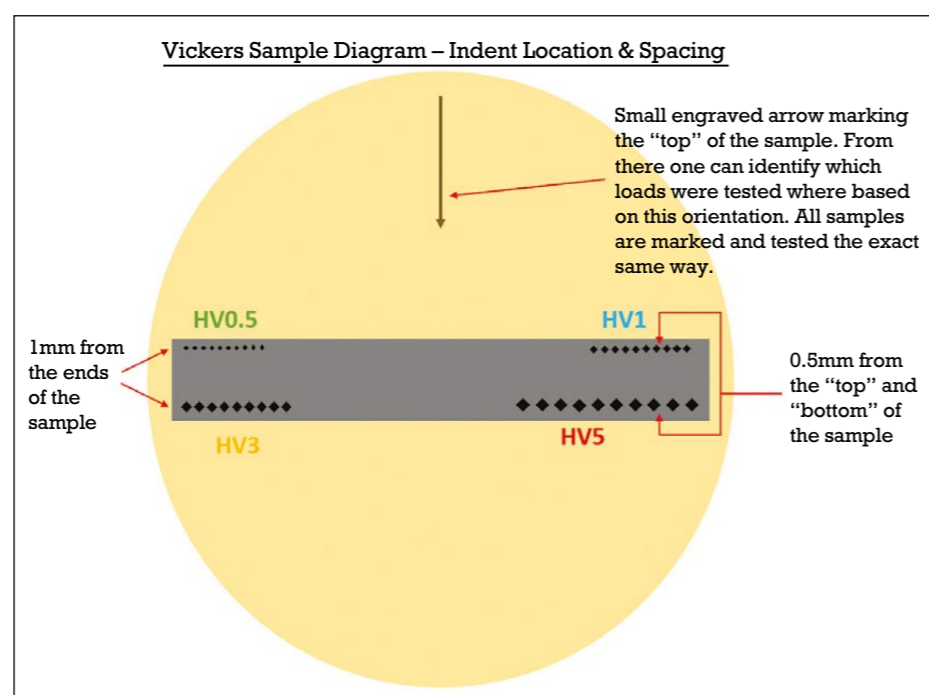

Figure 1. Vickers micro-hardness location

checked from the center of the section and evenly spaced between the indentations. **Vickers hardness testing procedure:** Hardness was checked from a polished surface and divided into four segments. Each segment is used as shown in Figure 1. The depth of the indentation is 0.5 mm below the surface and a minimum 1 mm away from the edge.

5. Evaluation methods

Data was collected from the four different laboratories representing three duplex alloys and four different hardness ranges per grade. Each individual sample had ten indentation data of Rockwell C hardness and Vickers hardness with loads of 0.5 kg, 1 kg, 3 kg, and 5 kg from each lab. The margin of error was reviewed with a 95% confidence interval by material grade, testing laboratory, and amount of cold working. For this test, the desired margin of error is chosen as less than 2%. The conversion between Rockwell C versus Vickers is reviewed by using the average of all indentations by the Vickers scale compared to Rockwell C hardness values. Linearity between Vickers scales against Rockwell C was compared, and the overall average linearity formula was recommended.

Results and discussion

1. Relative accuracy of the data

The overall average "Relative Accuracy percentage with 95% Confidence"

("% RA") was 1.3%, while the % RA result of each was for lean-duplex 1.5 %, duplex 1.1%, and super-duplex 1.2%. The % RA Average by Vickers load scales was 1.6 % of 0.5 kg, 1.3% of 1 kg, 1.0% of 3 kg, and 1.0% of 5 kg load. The % RA by the grades showed that duplex and super-duplex using load scales 3 kg and 5 kg ranged 0.8% to 1.1% while lean duplex using 0.5 kg load was 1.9%. There was no significant difference by the cold reduction amounts of 0%, 5%, 10%, 15% and all showed 1.55% to 1.6%. The overall average differences by the testing laboratories varied at 1.1%, 1.3%, 1.8% and 2.1%. Based on the average % RA, the following observations can be made:

- From the sample grade selection viewpoint, S32101 showed 0.3% to 0.4% greater variation (less reliable) than the other two grades S32760 and S32205.
- Vickers load scale view, 0.5 kg load scale showed a 0.6% greater variation than 3 kg and 5 kg load scale.
- Cold reduction amounts view, all samples were uniform within 0.05%.
- Overall % RA for this analysis was 1.0 % combining laboratories.

2. Variation between Vickers load scales

Figure 3 shows the hardness conversion relationship between Rockwell C versus Vickers with load scales of 0.5 kg, 1 kg, 3 kg, and 5 kg and a linear trendline of each scale shows very similar results.

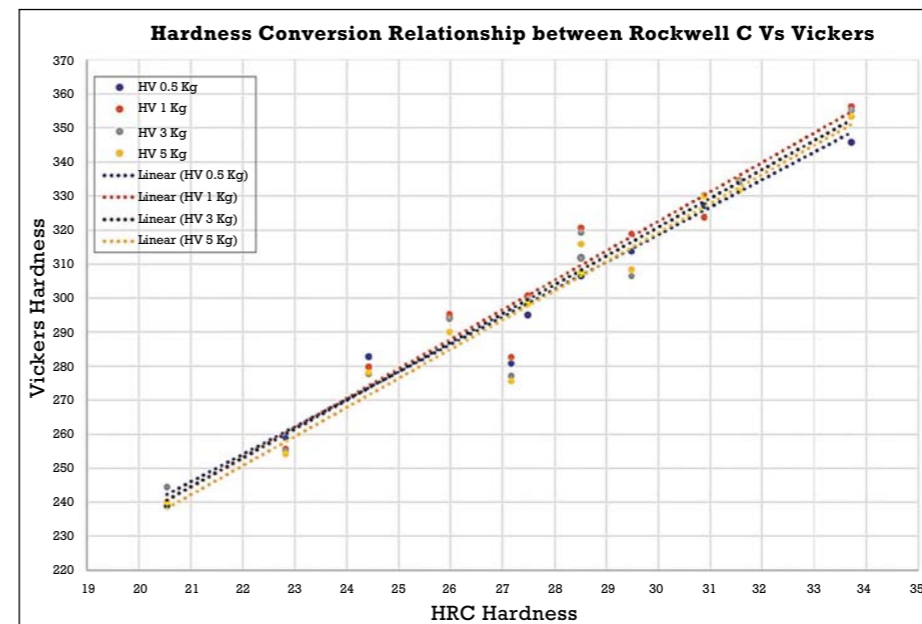

Figure 3. Hardness conversion relation between Rockwell C versus Vickers

Conclusion

In this research study, the correlation between the Rockwell C and various Vickers scales were evaluated and documented. Tests were performed using UNS S32101, S32205 duplex and S32760 super-duplex stainless steel with various amounts of cold-

worked material in strip form. Different testing method options were evaluated to define the proper methodology and the reliability of each testing laboratory was reviewed. Each of the Vickers scales against Rockwell C scale were plotted as comparison.

Results in this experiment are summarized by the following formula (**WTC Study: HRC- HV Duplex Conversion**):

$$HV = (8.444 \times HRC) + 67.0$$

or

$$HRC = (HV \times 0.1184) - 7.9$$

where HV = Vickers hardness
HRC = Rockwell C hardness

The proposed formula can be used for the majority of duplex and super-duplex grades and give a valuable correlation for hardness within the range 20 to 35 HRC and 250 to 350 Hv. The present work does not deal with hardness relevance to properties but only Rockwell/Vickers conversions.

Acknowledgements

The authors would like to acknowledge the team at Webco Industries TechCenter laboratory for performing the hardness measurements and post-test analysis of the samples. Similarly, we would like to thank Daniel Eyzop and Outokumpu R&D team for facilitating the acquisition of the samples used in this study as well as performing the hardness measurements. Lastly, we would like to thank Ivan Morales and Exxon Mobil Metallurgical Laboratory for performing the hardness measurements.

Don't miss the next Duplex World Update!

This is the first issue of Duplex World Update, a collection technical articles and information to serve the global duplex stainless steel community. Please feel free to share it with your network and all those who are interested in the manufacture and use of corrosion resistant alloys. To ensure that you don't miss the next issue, please send me an email and I will add you to the free mailing list.

If you'd like to contribute an article to the next Duplex World Update or Stainless Steel World magazine, please contact me to discuss the possibilities.

Best wishes,
Joanne McIntyre
Editor in Chief, Stainless Steel World
Conference Organiser, Duplex World
Tel: +31 575 585 298
Email: j.mcintyre@kci-world.com



Enjoy reading twice-weekly technical articles by following our Stainless Steel World Showcase page on LinkedIn! It's a meeting place for the corrosion resistant alloy community.

Our two dedicated materials groups on LinkedIn, called Stainless Steel World and Duplex Stainless Steel, are also a source of frequently updated news and discussion for the global community.

(click on the images below)

